

# Rainwater Harvesting | Livestock

Billy Kniffen, County Extension Agent-Agriculture and Natural Resources; and Rick Machen, Associate Professor and Extension Livestock Specialist; The Texas A&M University System

Water can be a limiting factor when grazing livestock on rangeland. A lack of stock water will prohibit rangeland use by livestock during certain seasons of the year or may require hauling water during dry months or drought conditions. Improper distribution of watering sites will contribute to the following:

- Excessive grazing in areas near water sources.
- Uneven utilization of the rangeland.
- Livestock traveling long distances to get to water which reduces grazing time, forage intake, weight gain or milk production.
- Loss of forage from excessive trailing and trampling.

## Water Requirements of Livestock

The following factors demonstrate how water consumption is influenced by the type and physiological status of livestock, nature of the forage and weather conditions:

- Green forage is higher in moisture content than dry forage and reduces water consumption.
- High temperatures increase consumption, while cool temperatures reduce consumption.

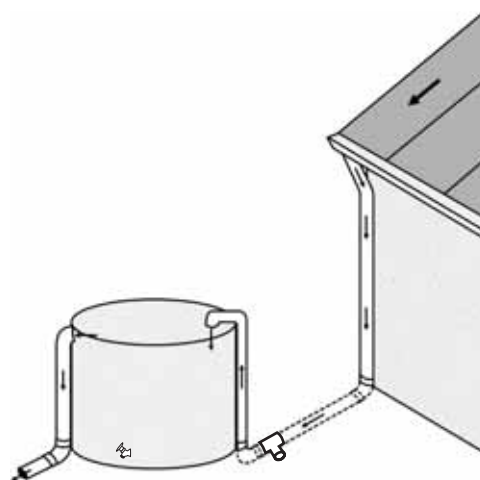

Figure 1. A typical rainwater harvesting system uses a roof, gutters, downspout and pipes underground, and backup into the top of the collection tank. This prevents livestock from damaging the pipes and allows the tank to be much further away from the shed. Unless there is a drain along the lower pipe, the standing pipes will contain water that is susceptible to freezing.

- Increased humidity in the air reduces daily consumption.
- Water consumption increases with age, weight, pregnancy and lactation.

**Table 1. Average daily consumption of water by various livestock species.**

Cattle	7 to 18 gallons
Horses	8 to 18 gallons
Sheep and goats	1 to 4 gallons

*General rule:* Provide 2 gallons of water per 100 pounds of body weight daily.

## Sources of Water

Rivers, streams, springs and existing stock ponds provide the least expensive source of water. Water wells provide water in many locations where surface water is not available. Windmills, solar powered pumps or electric submersible pumps, and piston-engine driven pumps are used to bring water to the surface. Another option may be rainwater captured in a storage container (tank) as a supplemental or as the sole source of water for livestock.

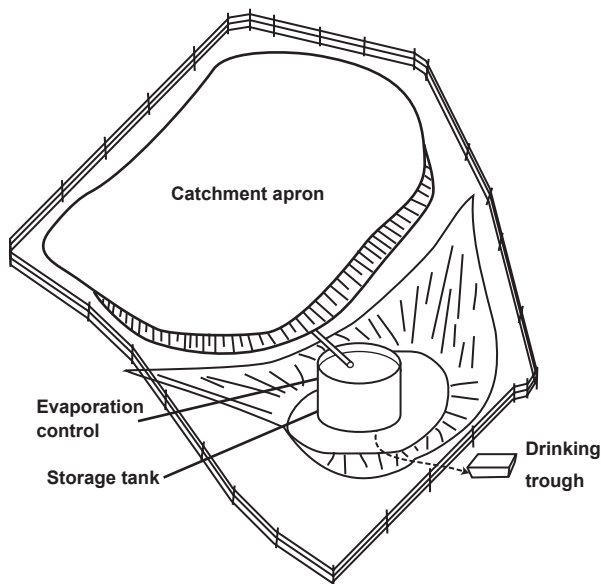

**Figure 2.** This rainwater harvesting system uses a prepared surface of concrete, rock or a sealing material to shed the rainfall. The rainwater is then diverted into the top of the collection tank.

## Rainwater Capture

Rainwater capture is done with a collection surface, conveyance to a storage tank and a watering trough. You can capture rainwater as runoff from a house, barn, rain barn or specially prepared surface area on the ground. During a one-inch (25.4 mm) rainfall, approximately 0.6

gallon (2.3 l) of water falls on each square foot (0.09 m<sup>2</sup>) of surface area. Runoff is collected more efficiently from smooth surfaces, such as tin roofs. Efficiency decreases as the surface becomes rougher and more porous. You can capture runoff from an existing or newly constructed roof (or a "paved" area on a hillside) surface conveyed through guttering and piping, cleaned with a roof washer and/or screen, and stored in a collection tank for livestock.

The two most expensive parts of the system are the roof or paved surface and the storage tank. If an existing system (barn roof and storage tank) is in place, the cost to add rainwater to the system is minimal. In some areas of the western United States, the soil or rock is treated to shed water, and the runoff is collected at a low point for wildlife and/or livestock. Storage tanks can be made of concrete, fiberglass, corrugated metal (with or without special liners), steel or polyethylene. Polyethylene tanks are the least expensive (by per stored gallon) up to approximately 4,000 gallons. Corrugated metal tanks with special liners are also a cost effective option. However, local availability may dictate the container choice. Covered tanks reduce evaporation and keep water cleaner. Algae must have sunlight to grow. By using translucent material and closing the top, algae problems will be minimal.

All livestock prefer to drink cool, clean, fresh water. Smaller (more narrow and shallow) watering troughs allow more frequent water replacement, thus keeping water cooler and fresher. Larger herds require more linear trough space to allow more animals to drink at the same time. Evaluate fill rate to ensure water is readily available for livestock. For sheep and goats, troughs need to be cleaned regularly to prevent parasite and disease contamination. Consider small/young animals that may accidentally fall into troughs and provide them a way to escape.

Most troughs use a float valve to maintain water level. Protect floats and valves by keeping livestock and wildlife away from the hardware. Place the water trough at a lower elevation than the tank to allow gravity flow from the tank to the trough. If the tank and trough are at the

same elevation, only the tank volume above the trough float is available water. If the storage tank is lower than the watering trough, the water must be pumped up hill.

## How much water do you need?

The amount of water needed depends on the kind of animal, number of animals, annual rainfall and the expected length of time between rainfalls. In addition to domestic livestock requirements, allow for some use by wildlife when calculating water demand. The lower the average annual rainfall, a larger roof and storage container are needed, as the following examples demonstrate:

### Example # 1:

2 mature horses in a 30-inch annual rainfall region with rare occasions of 2 months between significant rainfalls.

2 horses x 10 gallons of water per day = 20 gallons of water consumed per day.

20 gallons x 60 days of storage = 1,200 gallons of water storage needed as a minimum.

Capturing 1,200 gallons of water in a 1" rainfall requires a 2,000-square-foot roof (2,000 sq' x .6 gal/1" rainfall = 1,200 gallons).

Capturing 1,200 gallons of water in a 2" rainfall requires a 1,000-square-foot roof (1,000 sq' x .6 gal/1" rainfall = 1,200 gallons).

### Example # 2:

10 sheep in a 20-inch annual rainfall region with rare occasions of 3 months between significant rainfalls.

10 sheep x 4 gallons of water per day = 40 gallons of water consumed per day.

40 gallons x 90 days of storage = 3,600 gallons of water storage needed.

Capturing 3,600 gallons of water in a 1" rainfall requires a 6,000-square-foot roof (6,000 sq' x .6 gal/1" rainfall = 3,600 gallons). A 3" rainfall only requires a 2,000-square-foot roof.

Livestock requirements in these calculations can be adjusted by increasing or decreasing storage capacity while inversely decreasing or increasing the roof surface area. Also, if supplemental water is available or can be provided during dry times, you may reduce the surface area or storage capacity.

Also, in areas where rainfalls of 1" or more are frequent, you may not need to capture the total amount during a single rainfall. Thus, the catchment area and storage tank size may be reduced or increased. A chart is listed as a resource in the following section to help you determine a water budget more accurately. These calculations do not include evaporation losses from the storage tank or watering trough.

## For More Information

Texas Cooperative Extension Bookstore  
<http://tcebookstore.org>

- Reference Guide for Texas Ranchers, B-6101
- Rainwater Harvesting, B-6153
- Harvesting Rainwater for Wildlife, B-6182

TCE Rainwater Website with on-line calculator  
<http://rainwaterharvesting.tamu.edu>

Cattle Network.com  
<http://www.cattlenetwork.com/>



This publication was funded by the Rio Grande Basin Initiative administered by the Texas Water Resources Institute of Texas Cooperative Extension, with funds provided through a grant from the Cooperative State Research, Education, and Extension Service, U.S. Department of Agriculture, under Agreement No. 2005-45049-03209.

**Texas A&M AgriLife Extension Service** [AgriLifeExtension.tamu.edu](http://AgriLifeExtension.tamu.edu)

More Extension publications can be found at [AgriLifeBookstore.org](http://AgriLifeBookstore.org)

Educational programs of the Texas A&M AgriLife Extension Service are open to all people without regard to race, color, sex, disability, religion, age, or national origin.

---

The Texas A&M University System, U.S. Department of Agriculture, and the County Commissioners Courts of Texas Cooperating.